

# Penna

Designed by Studio Gorm, 2020

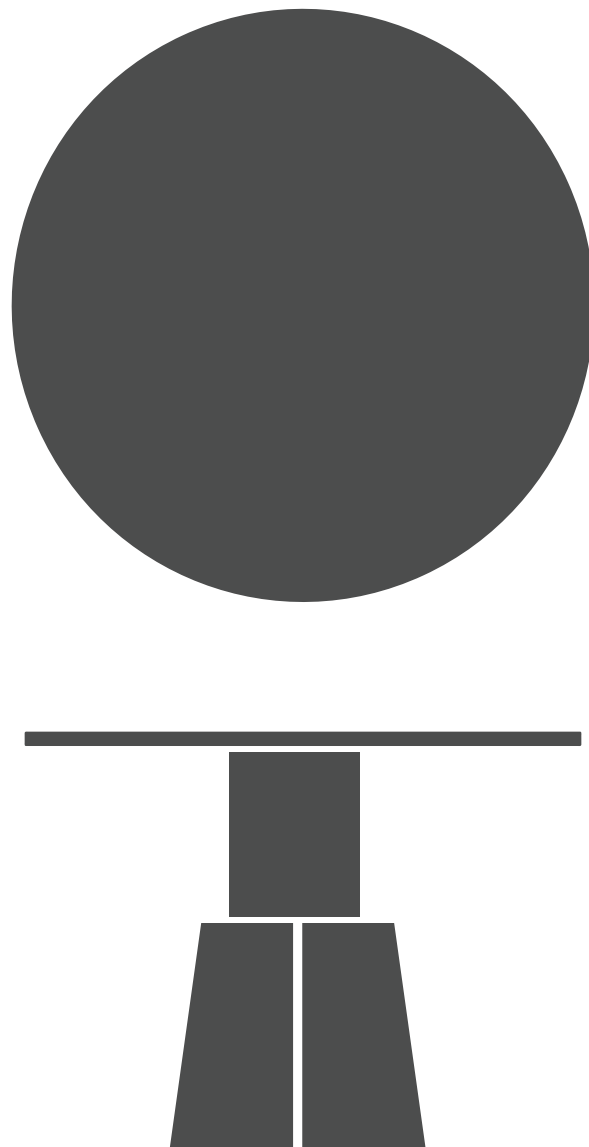

Height Adjustable Cafe Table  
SG01-T6-HAT-48D-MA

**memo**

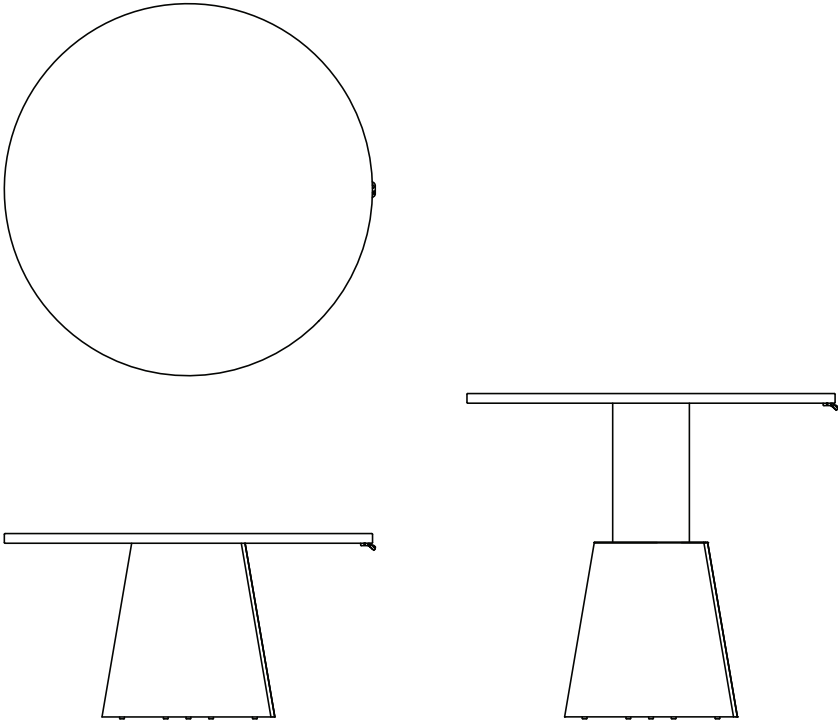

**Meeting Table** SG01-T6-HAT-48D-MA  
A crafted wood dining table composed of a conical base and a height adjustable, circular top.

Depth	Width	Height
48"	48"	24-42"

**Features**

- Coordinated with a family of lounge seating and tables.
- Simple Shaker-inspired shapes and volumes provide a calming and understated visual language.
- Solid wood edge band protects and reinforces the perimeter shape of the top
- Resilient finishes provide longevity for vivid color, texture, and material protection within commercial applications.
- Base and edge wood available in a variety of finishes to meet a wide range of interior schemas and palettes.
- Top surface available in matching Veneer, or natural Forbo Linoleum for a multitude of patterns, colors, and textures.
- Height range between 24" - 42" using an electrically powered lift.
- Available in custom top sizes and materials upon request

**Options**

Tops available in Wood, or Forbo Linoleum.

**Product Weight**

137 lbs (61,2 kg) - excluding ballast

**Specifiable Materials**

Wood (base, edge, top): Catalyzed Lacquer over Ash or Walnut, Stain → Memo Finishes Page  
Painted finish on cilumn shroud, Paint → Memo Finishes Page

**Colors and Finishes**

Please see our Finishes Palette online to review actual swatches, specs, and to order samples → Memo Finishes Page

**Content and Construction**

Edge Band: Solid wood

Frame interior: Plywood

Base Wrap: Veneer

Top surface: Veneer, or Forbo over a plywood core

Glides: Molded nylon

Wood Finish: Catalyzed Lacquer, Stain

**Weight Capacity**

200 lbs (90,7 kg)

**Testing**

Memo products are designed to meet the requirements of the BIFMA test protocol and are also subject to additional performance requirements in order to withstand the rigors of commercial interiors.

For specific testing information, please contact us at [info@memofurniture.com](mailto:info@memofurniture.com).

**Environmental**

For inquiries regarding Greenguard, MBDC, LEED, and LBC, please contact us at [info@memofurniture.com](mailto:info@memofurniture.com).

**Notes**

Bases ship with sandbags in certain models, for ballast.

Designed and Made in Seattle, Washington, USA.

# Penna

Designed by Studio Gorm, 2020

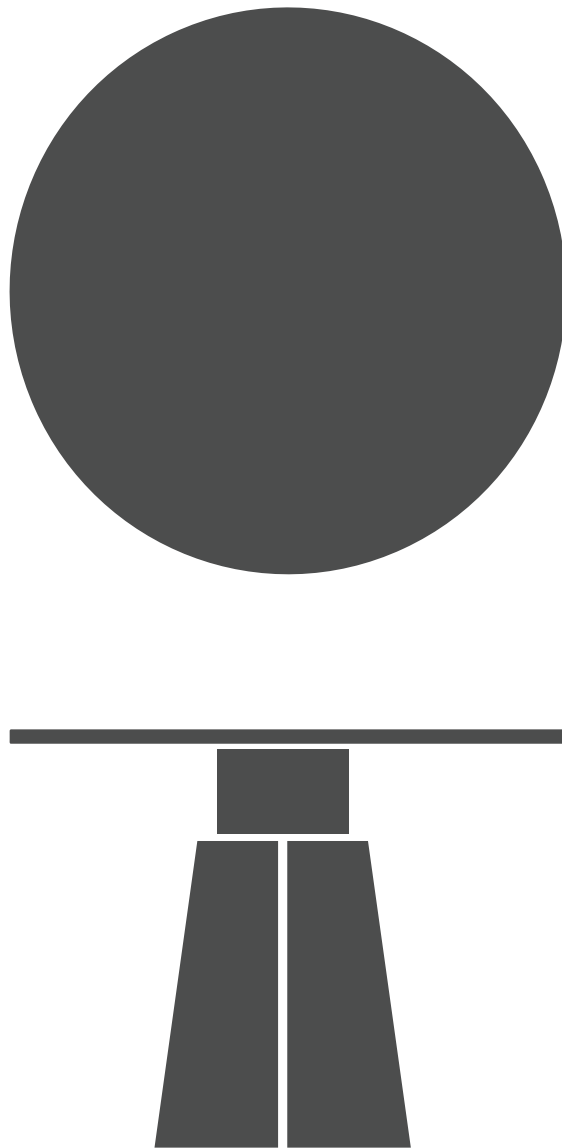

Height Adjustable Cafe Table  
SG01-T6-HAT-48D-MB

**memo**

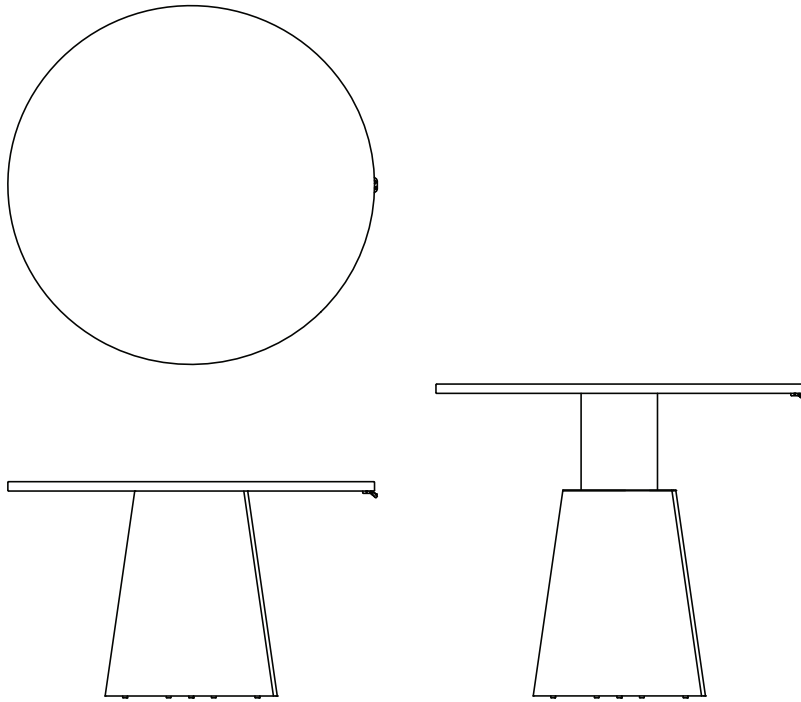
**Meeting Table** SG01-T6-HAT-48D-MB

A crafted wood dining table composed of a conical base and a height adjustable, circular top.

Depth	Width	Height
48"	48"	29-42"

**Features**

- Coordinated with a family of lounge seating and tables.
- Simple Shaker-inspired shapes and volumes provide a calming and understated visual language.
- Solid wood edge band protects and reinforces the perimeter shape of the top
- Resilient finishes provide longevity for vivid color, texture, and material protection within commercial applications.
- Base and edge wood available in a variety of finishes to meet a wide range of interior schemas and palettes.
- Top surface available in matching Veneer, or natural Forbo Linoleum for a multitude of patterns, colors, and textures.
- Height range between 29" - 42" using an electrically powered lift.
- Available in custom top sizes and materials upon request

**Options**

Tops available in Wood, or Forbo Linoleum.

**Product Weight**

140 lbs (63,5 kg) - excluding ballast

**Specifiable Materials**

Wood (base, edge, top): Catalyzed Lacquer over Ash or Walnut, Stain → Memo Finishes Page

Painted finish on cilumn shroud, Paint → Memo Finishes Page

**Colors and Finishes**

Please see our Finishes Palette online to review actual swatches, specs, and to order samples → Memo Finishes Page

**Content and Construction**

Edge Band: Solid wood

Frame interior: Plywood

Base Wrap: Veneer

Top surface: Veneer, or Forbo over a plywood core

Glides: Molded nylon

Wood Finish: Catalyzed Lacquer, Stain

**Weight Capacity**

200 lbs (90,7 kg)

**Testing**

Memo products are designed to meet the requirements of the BIFMA test protocol and are also subject to additional performance requirements in order to withstand the rigors of commercial interiors.

For specific testing information, please contact us at [info@memofurniture.com](mailto:info@memofurniture.com).

**Environmental**

For inquiries regarding Greenguard, MBDC, LEED, and LBC, please contact us at [info@memofurniture.com](mailto:info@memofurniture.com).

**Notes**

Bases ship with sandbags in certain models, for ballast.

Designed and Made in Seattle, Washington, USA.